

[www.fulgorservice.it](http://www.fulgorservice.it)



# FULGOR SERVICE

## PROFESSIONAL AUDIO



PRODUCTS CATALOGUE

# FULGOR SERVICE PROFESSIONAL AUDIO SYSTEM AND TECHNOLOGIES FOR VOICE DIFFUSION

**FULGOR SERVICE** is an Italian company specialized in the production of professional broadcasting voice and acoustic treatment in reverberant structures; with an expertise gained in over 30 years of leadership in the field of amplification for Sacred buildings, boasting installations on three continents.

**FULGOR SERVICE** makes available to the customer the experience in the specific area combined with advanced technology acquired over the years, this allows to obtain an harmonious relationship between the voice, the aesthetics of the structure and ease of use of the system, thus meeting any requirement.

Over the years **FULGOR SERVICE** has designed and built numerous products without interrupting the activity of their Studio & Research department; products which has now become indispensable for the professional voice broadcasting in any building or open space; another division of **FULGOR SERVICE** technical staff constantly works in audio system design for Sacred buildings newly constructed and/or being restored, in partnership with professionals, Department of Fine Arts and Architects, to design and produce the best result as possible, respecting the style and the aesthetics of the structure to be sonorized.

**FULGOR SERVICE** success on the market is also due to its corporate policy: in fact, **FULGOR SERVICE**, thanks to its studio & design department, manufactures and installs its products, analyzing each needs and providing a project-type for single installation, remaining in constant contact with final users. A veritable success, confirmed by more than 15,000 systems realized in Catholic churches and various structures around the world and by the portable systems for processions, born in '88 and evolved very quickly.

**FULGOR SERVICE** products are designed, tested and manufactured directly in its factory in Arcola (La Spezia), on the basis of market requirements and the constant search for innovative and functional formulas. All **FULGOR SERVICE** brand product range is manufactured with Italian materials and highly skilled labor: this allows you to carry out targeted solutions by making changes even on standard products according to customer's special requirements.

From several years **FULGOR SERVICE** is a licensee of the software suite *EASE* (Enhanced Acoustic Simulator for Engineers) which has become essential for the simulation of electro-acoustic systems. The *EASE* software suite contains a valuable set of tools for studying, modeling and realistic simulation of the acoustic response of a sound system in a given environment, providing a comprehensive full audio analysis of detailed graphics.

Main *EASE* simulation advantages:

- provide customers with a realistic anticipation of the electro-acoustic behavior of the system;
- use the standard SPL measurement parameters, TSI, etc.
- highlight any problems impossible to evaluate without simulation;
- analyze and solve acoustic problems before they occur.

In the *EASE* software there is a library of the world's largest companies speakers, these can be entered with the program in the structures to understand the effective functioning of the audio system; this library also includes our Vertical, high range Fulgor Service speakers.

**FULGOR SERVICE**, thanks to its engineering department, analyzes each needs and provides free project-type for the individual installation, detailed and personalized quotes.

**FULGOR SERVICE** today boasts a long tradition of professionalism and Italian quality, is installed throughout Italy and distributed by a sales network in various parts of the world, thanks to a network of 48 professional collaborators kept up to date by headquarters.

According to **FULGOR SERVICE** thinking, technology means simplifying a complex action.

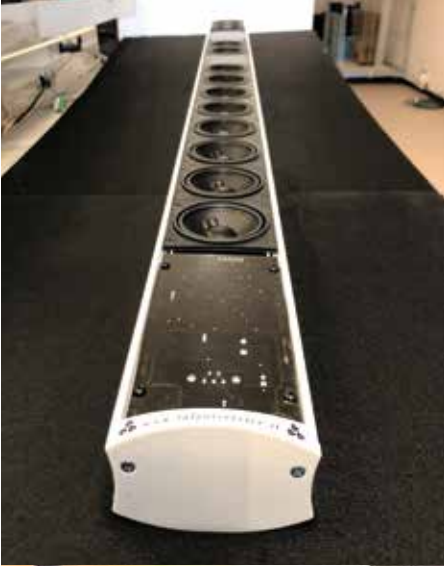
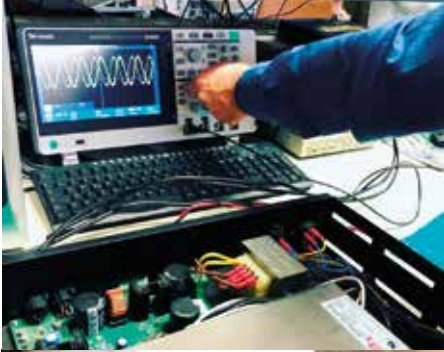

FREE

- **Vertical Rae** is the new line high efficiency Array speaker of Fulgor Service.
- **Vertical Rae** comes from the research and development of new high-efficiency speakers; these speakers arranged in array are able to obtain a dynamics and a sound pressure never had until today, by controlling the directivity both horizontally and vertically so as to limit the dispersion of the sound in the structure where they work.
- **Vertical Rae** thanks to new technical and mechanical solutions, is able to satisfy the most complex installations and provides a sound directivity control up to 30 meters, then a voice message reproduction with very high intelligibility and excellent natural timbre.
- **Vertical Rae** thanks to the new long and narrow design, it is easy to install in any environment, it can be installed in places of worship, conference rooms, council chambers, or where one needs higher quality sound with exceptional performance for voice.
- **Vertical Rae** is designed and built entirely in Fulgor Service, all components are made in Italy, this is to have an higher quality product and obtain the best voice performance.
- **Vertical Rae** is produced in two versions, 16 and 20 speakers to be used depending on the sound coverage needed in the structure to be amplified, the basic colors are White (RAL 9010) and Volcano (RAL 7006), it can be produced on demand in various colors using as reference the RAL scale.



Hardware and mounting brackets are provided to allow a discreet and functional installation.

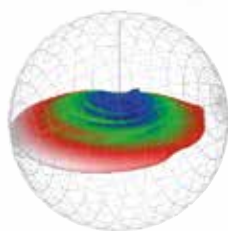

## TECHNICAL SPECIFICATIONS

### VERTICAL 16 RAE

- TRANSDUCERS \_\_\_\_\_ NUMBER 16
- FREQUENCY RESPONSE \_\_\_\_\_ 80 Hz ÷ 16.000 Hz
- MAX SPL @ 1 mt \_\_\_\_\_ 120 dB
- DISPERSION HORIZONTAL ANGLE \_\_\_\_\_ 180°
- DISPERSION VERTICAL ANGLE \_\_\_\_\_ 13°
- APPLICABLE POWER \_\_\_\_\_ up to 300 W
- SENSITIVITY 1 W, 1 mt \_\_\_\_\_ 87,6 dB
- IMPEDANCE \_\_\_\_\_ 8 Ohm
- MOUNTING SYSTEM \_\_\_\_\_ brackets "L" adjustable axis V axis H
- DIMENSIONS (WxHxD) mm \_\_\_\_\_ 100 X 1530 X 50
- WEIGHT \_\_\_\_\_ Kg 10,5

### VERTICAL 20 RAE

- TRANSDUCERS \_\_\_\_\_ NUMBER 20
- FREQUENCY RESPONSE \_\_\_\_\_ 80 Hz ÷ 16.000 Hz
- MAX SPL @ 1 mt \_\_\_\_\_ 122 dB
- DISPERSION HORIZONTAL ANGLE \_\_\_\_\_ 180°
- DISPERSION VERTICAL ANGLE \_\_\_\_\_ 10°
- APPLICABLE POWER \_\_\_\_\_ up to 300 W
- SENSITIVITY 1 W, 1 mt \_\_\_\_\_ 87,6 dB
- IMPEDANCE \_\_\_\_\_ 6 Ohm
- MOUNTING SYSTEM \_\_\_\_\_ brackets "L" adjustable axis V axis H
- DIMENSIONS (WxHxD) mm \_\_\_\_\_ 100 X 1900 X 50
- WEIGHT \_\_\_\_\_ Kg 13,7



# Vertical 16-20 RAE

High Efficiency  
Array Speakers



The images are purely illustrative and the details can be changed without any warning.

# Activo One System



Thanks to the development of new technologies, it was possible to design an innovative audio distribution system, efficient, reliable, simple to install and, above all, highly performant. **Activo One System** presents itself as the only system like this. With **Activo One System** for each playing point you can adjust the power, equalization and delay without necessarily changing the infrastructure. In fact, the **Activo One System** works with a normal cable line on which runs both the audio and power signal.

The requirements of modern sound systems and the care of the aesthetic / cultural heritage of Churches lead to design systems with few diffusion points; with a traditional system it is essential to create delay lines between the various audio fronts (phase alignment) and this involves the use of digital matrix, power units with many channels, and especially the preparation of many lines. With **Activo One System** this is no longer necessary since it is enough only one power supply and a minimum number of speakers connected between themselves with a simple bipolar cable (also already existing, as in most cases); each speaker, in fact, will handle with the right pressure-equalization-delay the relevant zone.

## Vertical Activo... the best Activo ever!

**Vertical Activo** is the digital amplified active speaker with **DSP**, the heart of the **Activo One System**, high-performance multipoint systems where high standards of quality and intelligibility are required. **Activo One System** guarantees greater dynamics, pressure and acoustic homogeneity in the structure to be amplified, thereby ensuring greater intelligibility and sound definition.

**Vertical Activo**, thanks to its array with high efficiency speakers, ensures dynamics, pressure and directivity control both on the horizontal and vertical axis, satisfying even the most demanding designers. **Vertical Activo** is designed and built entirely in **Fulgor Service**, all components are **made in Italy**, this is to have an higher quality product and obtain the best voice performance.

**Vertical Activo** is produced in three versions: S 4-speakers, L 9-speakers and XL-12 speakers to be used depending on the needed sound coverage in the structure to be amplified.

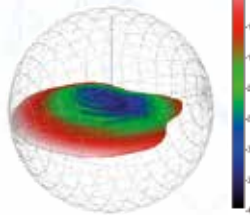

The images are purely illustrative and the details can be changed without any warning.

## TECHNICAL SPECIFICATIONS



POWER SUPPLY:

ALL-ONE

ALL-ONE LIGHT

- TECHNOLOGY: \_\_\_\_\_ ON-PoS
- PROTECTIONS: \_\_\_\_\_ antipump, inv. polarity, short circuit
- BANDWIDTH: \_\_\_\_\_ 50 to 18000 Hz
- COOLING: \_\_\_\_\_ forced by thermostatic fans
- POWER INPUT: \_\_\_\_\_ 230 V AC
- POWER OUTPUT: \_\_\_\_\_ 43÷44 V DC
- POWER: \_\_\_\_\_ 650 W \_\_\_\_\_ 400 W
- DIMENSIONS: \_\_\_\_\_ (LxDxH) 482x300x88 mm \_\_\_\_\_ (LxDxH) 210x260x88 mm
- WEIGHT: \_\_\_\_\_ 8 Kg \_\_\_\_\_ 1,8 Kg

## ACTIVO SPEAKER SPECIFICATIONS

- TECHNOLOGY: \_\_\_\_\_ DSP and ONE demux
- DSP: \_\_\_\_\_ on board 24 bit - 48 KHz frequency
- FINAL OUTPUT POWER: \_\_\_\_\_ 35 W RMS (65 W peak) at 8 Ohm
- PROTECTIONS: \_\_\_\_\_ on input signal, on reverse polarity on short circuit
- ANTI-BUMP CIRCUIT: \_\_\_\_\_ at switching on and switching off
- EQUALIZATION: \_\_\_\_\_ filter settings through a special controller
- BANDWIDTH BOARD: \_\_\_\_\_ 50 to 18000 Hz
- S/N RATIO: \_\_\_\_\_ better than 98 dB; distortion <0.3%
- COOL: \_\_\_\_\_ full natural circulation
- POWER INPUT: \_\_\_\_\_ 40 to 45 V DC
- SIGNAL INPUT: \_\_\_\_\_ ONE emux
- POWER: \_\_\_\_\_ requires dedicated power supply ALL-ONE
- ACTIVO S WEIGHT: \_\_\_\_\_ 3,5 Kg
- ACTIVO L WEIGHT: \_\_\_\_\_ 6,9 Kg
- ACTIVO XL WEIGHT: \_\_\_\_\_ 8,5 Kg
- ACTIVO S DIMENSIONS: \_\_\_\_\_ (HxWxD) 560x100x50 mm
- ACTIVO L DIMENSIONS: \_\_\_\_\_ (HxWxD) 1037x100x50 mm
- ACTIVO XL DIMENSIONS: \_\_\_\_\_ (HxWxD) 1314x100x50 mm

To perform the calibration of the DSP mounted on the DIGITAL ACTIVO board the specific **CONTROLLER** has to be installed.



the **Vertical Activo** basic colors are white (RAL 9010) and Volcano (RAL 7006), on demand it can be produced in various colors using as reference the RAL scale. Included is provided the hardware and mounting brackets that allow discreet and functional installation.



AMP PCB

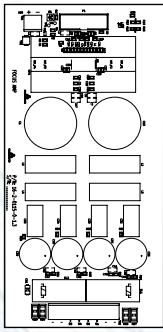

Logic PCB

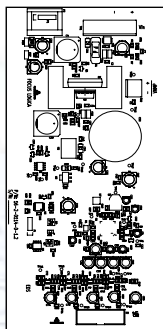

The new **Vertical Activo Focus** speaker is part of the **Activo One System** line; has two main features:

- It works through a common two-pole cable on which both the signal and the power supply flows with **ONE-PoS (Power over Signal)** technology.

- It can control the vertical directivity to address the sound towards the listener.

• **Activo Focus** has all the potential and features of the Activo One System line, with the novelty of being able to control the emitted audio beam "Focus". By connecting the new Activo audio system to the existing cable system we can: adjust the volume, give the delay (delay), direct the acoustic focus towards the listeners.

• With **Activo Focus**, Fulgor has developed its own technology with its own algorithm to direct the "Focus" on the vertical axis, towards the listener, integrating everything with his own well tested system Activo One System, obtaining a system of wide use, very easy to be installed and qualitatively performing.

• The technology used in **Activo Focus** is able to decode the signal and the power sent through a line cable from ALL-ONE, which is the power supply of the system. In each speaker you have the possibility to adjust volume, delay and equalization. In addition, the new **Activo Focus** has a more powerful integrated DSP and a 4-channel digital final,

which thanks to the specially designed algorithm directs the sound down. The individual loudspeaker groups of the **Activo Focus** speaker are piloted separately from the DSP and the final, the algorithm manages the different groups by changing and combining the main parameters (level, bandwidth, delay), so as to create a homogeneous, controlled and precise beam. The logic board for setting up **Activo Focus** is on the speaker, making it easier the management for the technician using intuitive configuration controller using the cable or WIFI.

• The technician has the possibility to manage the volume and the delay of the single speaker and manage the vertical angle of the focus of the speaker itself from 0° to -10° degrees.

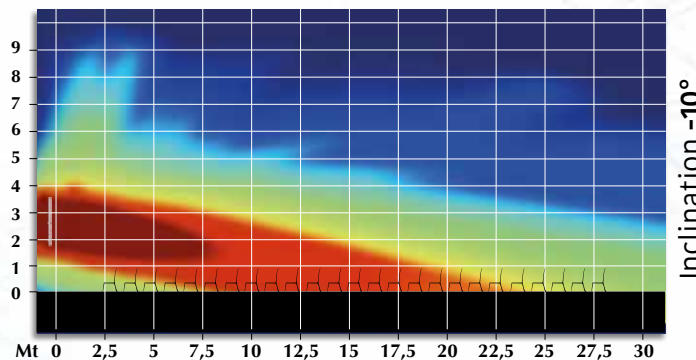
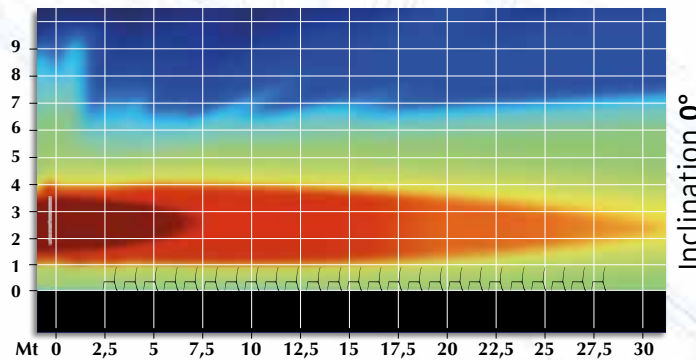

The images are purely illustrative and the details can be changed without any warning.

# Activo Focus

## ONE PoS System

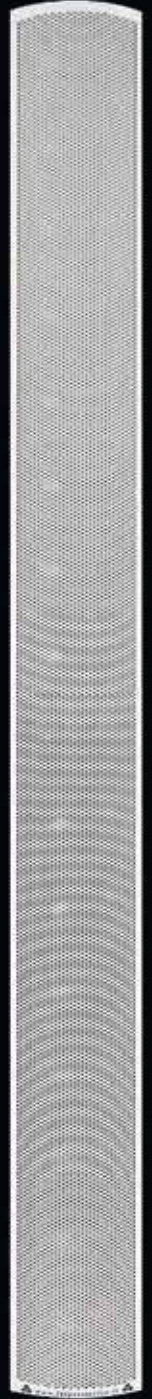

### TECHNICAL SPECIFICATIONS

- TECHNOLOGY: \_\_\_\_\_ DSP and **ONE-PoS**
- DSP: \_\_\_\_\_ integrated 28/56 bit - fs 48KHz
- FOCUS CONTROL: \_\_\_\_\_ 250 ÷ 18000 Hz
- DISTANCE OF THE ACOUSTIC BEAM: \_\_\_\_\_ controlled up to 20/22 meters
- DISTANCE FOR SHORT MESSAGE: \_\_\_\_\_ intelligibility up to 30 meters
- DISTANCE COSTANT USE: \_\_\_\_\_ intelligibility 20/22 meters
- POINTING ANGLES: \_\_\_\_\_ 0° -1° -2° -3° -4° -5° -6° -7° -8° -9° -10°
- INTEGRATED FINALS: \_\_\_\_\_ 4 in class D
- POWER FOR FINAL: \_\_\_\_\_ 50 W RMS (100 W on peak) on 8 Ohms
- PROTECTIONS: \_\_\_\_\_ 1 on the input signal, 1 on polarity inversion, 1 on short circuit
- ANTI-BUMP CIRCUIT: \_\_\_\_\_ 1 in power on and 1 in power off
- BANDWIDTH PCB: \_\_\_\_\_ 80 ÷ 18000 Hz
- S/N RATIO: \_\_\_\_\_ better than 98dB; distortion <0.3%
- COOLING: \_\_\_\_\_ integral with natural circulation
- INPUT SUPPLY: \_\_\_\_\_ 43 V DC
- INPUT SIGNAL: \_\_\_\_\_ ONE enmux
- POWER SUPPLY: \_\_\_\_\_ ALL-ONE dedicated power supply unit with **ONE-PoS** technology
- MAXIMUM CONSUMPTION: \_\_\_\_\_ 2500 mA
- VOLTAGE REGULATION: \_\_\_\_\_ local in linear technology
- WEIGHT: \_\_\_\_\_ 10,50 kg
- DIMENSIONS: \_\_\_\_\_ (HxVxD) 1606x100x50 mm



FREE

DSP  
DIGITAL SIGNAL PROCESSING  
**On board**

SUPPORT MADE IN ITALY

BUY OUR PRODUCTS

FULGOR SERVICE

1 2 3 4

# Directivity



TALST

POWER

# High Efficiency Directivity System



**Directivity** is the Fulgor Service audio system with directivity control of the emission lobe or sound beam. The technology of Directivity system includes a digital processor with dedicated algorithm, its own software D&D control, array speaker and power units 6-channel Class-D.

**Directivity** system allows to sonorize large environments with difficult acoustics, getting a clear and intelligible audio, thanks to software that is used to control the emission of the array both on the vertical (X) and horizontally (Y) axis, so as to acoustically cover only the listening area and not cause harmful reflections.

**Directivity** speaker is composed of groups of speakers separately connected to the power units, these are driven by the algorithm of the processor that allows it to function. The speakers applicable to the Directivity system are of two measures in accordance with the need for sound coverage required. They are available from a range of 25 mt to 45 mt.

## TECHNICAL SPECIFICATIONS

- BOARDS INTERNAL : \_\_\_\_\_ 2 DSP boards for the 8 outputs control
- BAND WIDTH: \_\_\_\_\_ 20 Hz to 20 KHz / -1 dB
- DISTORTION FACTOR : \_\_\_\_\_ < 0,005%
- TOTAL DYNAMICS: \_\_\_\_\_ 103 dB
- EXTERNAL POWER SUPPLY : \_\_\_\_\_ 230V AC
- AUDIO INPUT: \_\_\_\_\_ 4 micro line with XLR, balanced, phantom power from -60 dB to +20 dB
- INPUT IMPEDANCE : \_\_\_\_\_ 6,6 KOhm
- PHANTOM POWER : \_\_\_\_\_ selectable
- OUTPUT: \_\_\_\_\_ 8 x XLR balanced, +10 dB
- EQUALIZERS: \_\_\_\_\_ 9 parametric bands on out standard - 5 filters, parametric out on directivity
- DELAY: \_\_\_\_\_ 0,023 to 500 ms
- INTERFACE: \_\_\_\_\_ serial, RS-232 interface for programming
- USER INTERFACE: \_\_\_\_\_ RP6 panel
- PROCESSOR DIMENSIONS (WxHxD in mm): \_\_\_\_\_ 482 (431) x 45 x 200; 19" 1U
- PROCESSOR WEIGHT: \_\_\_\_\_ 2,40 Kg
- V. DIRECTIVITY DIMENSIONS (WxHxD in mm): \_\_\_\_\_ 100 x 1578 x 50
- V. DIRECTIVITY WEIGHT: \_\_\_\_\_ 11 Kg
- V. MAX DIMENSIONS (WxHxD in mm): \_\_\_\_\_ 2322 x 100 x 50
- WEIGHT V. MAX: \_\_\_\_\_ 16 Kg
- SPEAKER DIRECTIVITY CONTROL VIA SOFTWARE

## SOUND DIFFUSION PATTERN



10 mt 20 mt 30 mt 40 mt 45 mt

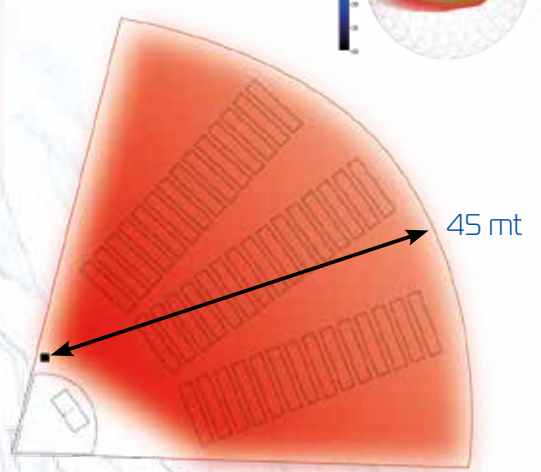

45 mt

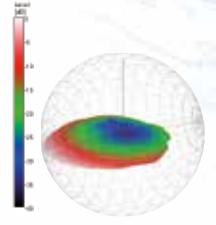

10 mt 20 mt 30 mt 40 mt 45 mt

The images are purely illustrative and the details can be changed without any warning.

- **Vertical** is the new speaker of the Fulgor Service line conceived, designed and built to achieve the best speech intelligibility in each structure.
- **Vertical** is an array speaker system that combines aesthetic slim to a sound quality at the highest level.
- **Vertical** is designed and built entirely in Fulgor Service, all components are made in Italy, this is to have a high quality product and best performance in the voice reproduction.
- **Vertical** is produced in various versions, with 2/4/6/8/10 speakers and equipped with autotransformer, to be used according to the sound power required in the structure to be amplified.
- **Vertical** is available in two colors, White (RAL 9010) and Volcano (RAL 7006), on demand it can be produced in various colors using as reference the RAL scale.



Hardware and mounting brackets are provided to allow a discreet and functional installation.

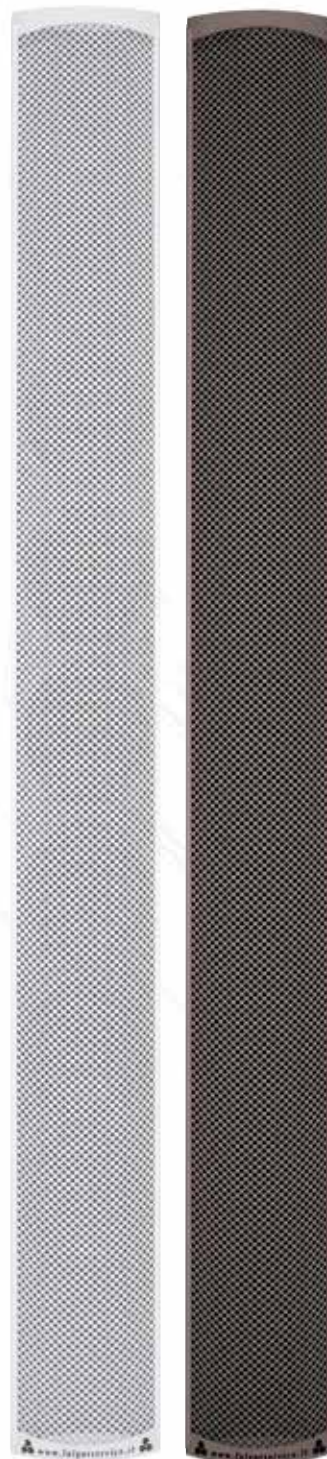
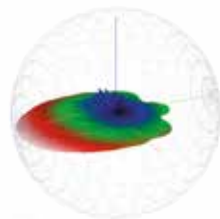

# Vertical 2-4 6-8-10

Array speakers



The images are purely illustrative and the details can be changed without any warning.

## TECHNICAL SPECIFICATIONS

### VERTICAL 2 - 4 - 6 - 8 - 10

• FREQUENCY RESPONSE	-----	80 Hz ÷ 16.000 Hz
• MAX SPL @ 1 mt	-----	99 dB
• DISPERSION HORIZONTAL ANGLE (RIF. V10)	-----	160°
• DISPERSION VERTICAL ANGLE (RIF. V10)	-----	25°
• APPLICABLE POWER	-----	30 W on 100V; 100 W at 64 Ohm
• IMPEDANCE	-----	64 Ohm, 330 Ohm, 660 Ohm, 1 KOhm, 2 KOhm, 3 KOhm
• SENSITIVITY 1 W, 1 mt	-----	89,6 dB
• MOUNTING SYSTEM	-----	"L" brackets adjustable axis V axis H
• DIMENSIONS (WxHxD) mm	V2=100x290x50; V4=100x473x50; V6=100x658x50; V8=100x845x50; V10=100x1020x50	
• WEIGHT KG	-----	V2=1,5; V4=2,4; V6=3,5; V8=5,5; V10=5,8



# R100 R200

## Wireless Microphone System



R100



R200



R100+R200 RACK



FS470

FS630

L100

P100

### MICROPHONES: "LAVALIER" L100 / "HANDHELD" P100

- FREQUENCY RANGE: \_\_\_\_\_ UHF 680~760MHz
- BANDWIDTH: \_\_\_\_\_ 24 MHz
- AF POWER OUTPUT: \_\_\_\_\_ L100: 50mW - P100: 30mW
- ISSUE SPURIE.: \_\_\_\_\_ < -55dBc
- TYPE DISPLAY: \_\_\_\_\_ LCD
- OSC TYPE: \_\_\_\_\_ PLL synthesized
- MAX. INPUT LEVEL: \_\_\_\_\_ L100: 0dBV - P100: 140dB SPL
- TYPE OF BATTERIES: \_\_\_\_\_ AA x 2 alkaline
- COATING: \_\_\_\_\_ Plastic wrinkled
- L100 DIMENSIONS (WxHxD) mm: \_\_\_\_\_ 63 x 82 x 22
- L100 WEIGHT: \_\_\_\_\_ about 81gr excluding batteries
- P100 DIMENSIONS: \_\_\_\_\_ Ø 50mm - Lenght 233mm
- P100 WEIGHT: \_\_\_\_\_ about 246gr excluding batteries

**Fulgor Service** uses an high performing wireless microphone system with advanced technology, which is part of the professional range. Both transmitters and receivers use multifrequency UHF PLL digital technology and provide 100 channels usable for solve problems of interferences in any place. This wireless microphone system is built in Fulgor Service with special technical devices that can cover very important distances (100 meters in open field), with no signal loss. The models vary from single receiver to double receiver. Both models are provided with autoscanner button to automatically search for free channels in the environment where they have to be installed and the antennas can be mounted both on front and rear side.

All receiver modules can be combined with handheld or lavalier (body-pack) transmitter, headset, foulard or with the thinnest flesh-colored microphones.

### TECHNICAL SPECIFICATIONS

#### R100 RECEIVER

- RECEIVER: \_\_\_\_\_ single
- CHASSIS: \_\_\_\_\_ EIA standard 19" 1/2 unit
- RECEIVING MODE: \_\_\_\_\_ Diversity
- FREQUENCY RANGE: \_\_\_\_\_ UHF 680~760MHz
- ANTENNA: \_\_\_\_\_ 2 - back or front panel. Removable
- PRESET: \_\_\_\_\_ 100 preset channels
- OSC TYPE: \_\_\_\_\_ PLL synthesized
- SENSITIVITY: \_\_\_\_\_ 10dBµV, S/N>80 dB
- S/N RATIO: \_\_\_\_\_ >106dB(A)
- THD: \_\_\_\_\_ <0.5% @ 1KHz
- FREQUENCY RESPONSE: \_\_\_\_\_ 50Hz~18KHz with high pass filter
- SQUELCH: \_\_\_\_\_ "PiloTone & NoiseLock" dual-squelch circuit
- MAXIMUM LEVEL OUTPUT: \_\_\_\_\_ switch 2 levels: Line e Mic
- POWER: \_\_\_\_\_ AC external adapter, 12~15V DC, 1A
- DIMENSIONS (WxDxH) mm: \_\_\_\_\_ 210 x 45 x 200
- WEIGHT: \_\_\_\_\_ 1 Kg

#### R200 RECEIVER

- RECEIVER: \_\_\_\_\_ double
- CHASSIS: \_\_\_\_\_ EIA standard 19" 1/2 unit
- RECEIVING MODE: \_\_\_\_\_ Diversity
- FREQUENCY RANGE: \_\_\_\_\_ UHF 680~760MHz
- ANTENNA: \_\_\_\_\_ 2 - back or front panel. Removable
- PRESET: \_\_\_\_\_ 100 preset channels
- OSC TYPE: \_\_\_\_\_ PLL synthesized
- SENSITIVITY: \_\_\_\_\_ 10dBµV, S/N>80 dB
- S/N RATIO: \_\_\_\_\_ >106 dB(A)
- THD: \_\_\_\_\_ <0.5% @ 1KHz
- FREQUENCY RESPONSE: \_\_\_\_\_ 50Hz~18KHz with high pass filter
- SQUELCH: \_\_\_\_\_ "PiloTone & NoiseLock" dual-squelch circuit
- MAXIMUM LEVEL OUTPUT: \_\_\_\_\_ switch 2 levels: Line e Mic
- POWER: \_\_\_\_\_ AC external adapter, 12~15V DC, 1A
- DIMENSIONS (WxDxH) mm: \_\_\_\_\_ 210 x 45 x 200
- WEIGHT: \_\_\_\_\_ 1,1 Kg



The images are purely illustrative and the details can be changed without any warning.

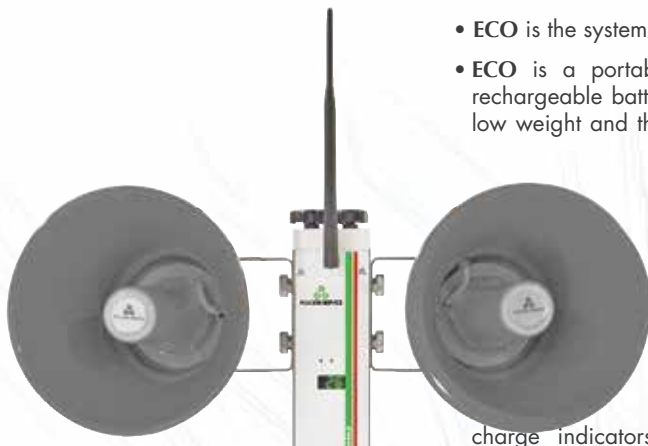

USB connection

Connection with articulated joint between the device and battery pack



- ECO is the system for procession by **FULGOR SERVICE**.
- ECO is a portable device, lightweight and easy to use with rechargeable batteries, can be transported anywhere thanks to its low weight and the possibility to separate the electronics from the battery pack thus reducing the size.
- ECO is an essential tool to spread voice or music outdoors or where we do not want wires, thanks to the rechargeable lithium polymer batteries we can have a life of 6 hours, one or two professional microphones 100 channels PLL (100 mt flow rate in open field), a USB input with controls, an AUX input (3.5mm jack), an internal antilarson to more easily handle the volume, battery charge indicators and indicators of the wireless microphone channel.
- ECO covers an area up to 300 meters thanks to the powerful amplifier and high performing horns that can rotate at 360° and spread the sound evenly with excellent quality, making it understandable to all participants the message transmitted.
- ECO is supplied with transmitter (professional wireless microphone to handle), 2 horns, a rod holder, a battery pack, a carrying belt, a battery charger and user manual.
- ECO/P is the radio link system to cover long distances, when it needs to combine two or more ECO, with radio link we have the possibility of multiply indefinitely ECO receivers, in fact ECO/P using its antenna with radio module, emits a UHF signal which cover a radius of about 1.5 KM in open field.
- **OPTIONAL:** Double radio microphone - additional battery pack - specific speakers for indoor - carrying bag.

## TECHNICAL SPECIFICATIONS

### RADIO LINK (ECO/P only)

- POWER: \_\_\_\_\_ according to user's requirements
- ANTENNA: \_\_\_\_\_ 5/8 rubber
- AVERAGE ABSORPTION: \_\_\_\_\_ 650 mA
- POWER SUPPLY: \_\_\_\_\_ 12 V DC stabilized

### AMPLIFIER/PRE

- MIC IN SENSITIVITY: \_\_\_\_\_ 2,5 mV
- AUX IN SENSITIVITY: \_\_\_\_\_ 150 mV
- POWER SUPPLY: \_\_\_\_\_ 16 V DC
- POWER: \_\_\_\_\_ 25 W - 4 Ohm with constant supply 16 V DC

### RECEIVER

- FREQUENCY: \_\_\_\_\_ UHF 100 ch
- RECEIVER MODULE: \_\_\_\_\_ sub tone squelch
- SPURIOUS SUPPRESSION: \_\_\_\_\_ >80 dB
- ABSORPTION: \_\_\_\_\_ ~ 100 mA
- POWER SUPPLY: \_\_\_\_\_ 10-15 V DC

### HORN SPEAKER TUIS

- TEXTURE: \_\_\_\_\_ aluminium
- MAXIMUM POWER: \_\_\_\_\_ 15 W
- IMPEDANCE: \_\_\_\_\_ 8 Ohm

### RECHARGEABLE BATTERIES

	ECO	ECO/P
• BATTERY PACK :	single	double
• TYPE:	4Ah - 16,8V DC	8Ah - 16,8V DC
• AUTONOMY:	about 6 hours	about 6 hour
• CHARACTERISTICS:	lithium	lithium

### DIMENSIONS

- TOTAL LENGHT in mm: ECO: 1390 - ECO/P: 1650
- WEIGHT: 4,1 Kg 5,8 Kg



ECO Voice Amplification Professional System  
ECO/P Long-range Radio Link

# M6 v3

## DSP Digital Audio Matrix

- M6 v3 is a digital matrix provided with 6 inputs, 4 outputs, 4 antilarsen and DSP with ability to integrate into any new or existing sound system.
- M6 v3 has 6 input equalizers and 4 output equalizers, gate, delay and automatic opening system for microphones.
- M6 v3 is a new equipment produced by Fulgor Service that fits into the high range of the audio market, when you need to manage multiple signals and distribute them to multiple outputs processing delays, equalizations, antilarsen, noise gate and presets.
- M6 v3 is a tool that allows you to get a good speech intelligibility in any environment where it is installed, increasing the efficiency of the audio system and increasing the SPL.
- M6 v3 is configured at installation time using a PC with proprietary software.
- M6 v3 is supplied in 1U standard rack and provided with a recall presets panel.
- M6 v3 is easy to manage for the final customer.

### TECHNICAL SPECIFICATIONS

- 6 inputs and 4 outputs balanced XLR mic / line.
- 6X4 matrix by pass
- configurable and remotable potentiometers
- 3 parametric equalizers on each input
- 4 antilarsen assignable outputs on dual technology
- 4 noise gate
- 4 delay
- 6 parametric EQ on every output
- 32 configurable presets
- AutoMixer with advanced logic
- Dedicated software
- Compressor
- Phantom
- Gain up to 50 dB input



RP6 PANEL



### ACCESSORIES

- **SUPPLIED:**  
RP6 PANEL - PRESET RECALL WITH 6 ITEMS
- **OPTIONAL:**  
M-CONTROL INTERFACE TOUCH



### GENERAL SPECIFICATIONS

- NUMBER OF BITS \_\_\_\_\_ 24
- DYNAMICS \_\_\_\_\_ 96 dB
- INPUT LEVEL \_\_\_\_\_ -50 dB +50 dB
- IMPEDANCE INPUT \_\_\_\_\_ 6K Ohm
- OUTPUT LEVEL \_\_\_\_\_ -60 dB + 6 dB
- INPUT LEVEL MAXIMUM \_\_\_\_\_ + 50 dB
- OUTPUT IMPEDANCE \_\_\_\_\_ 100 Ohm
- FREQUENCY RESPONSE \_\_\_\_\_ 20HZ/20000Hz
- OPERATING TEMPERATURE \_\_\_\_\_ -5+40° C
- SAMPLING FREQUENCY \_\_\_\_\_ 42 KHz
- POWER SUPPLY \_\_\_\_\_ 230V ± 10% -50 Hz
- POWER CONSUMPTION \_\_\_\_\_ 10 VA
- DIMENSIONS (WxHxD) mm \_\_\_\_\_ 483X45X200 - 1U standard rack
- WEIGHT \_\_\_\_\_ 2,5 KG

### SOFTWARE PROGRAMABLE SPECIFICATIONS

- **ANTILARSEN** (2 parameters adjustable with double algorithm)
  - PHASE \_\_\_\_\_ from 1 to 7,5 ms / from 0,1 to 2 Hz
  - FREQUENCY \_\_\_\_\_ from 0,1 to 2 Hz
- MATRIX BY PASS \_\_\_\_\_ 6 X 4
- NOISE GATE (3 adjustable parameters) \_\_\_\_\_ threshold, delay, slope
- DELAY ON EVERY CHANNEL \_\_\_\_\_ from 0 to 64 mt
- PARAMETRIC FILTERS
- 32 PRESET SELECTABLE BY REMOTE CONTROL
- REVERSE PHASE 180° PROGRAMMABLE ON INPUT AND OUTPUT

# M12 v3

## DSP Digital Audio Matrix



- M12 v3 is a digital matrix provided with 12 inputs, 8 outputs, 8 antilarsen and DSP with ability to integrate into any new or existing sound system.
- M12 v3 has 12 input equalizers and 8 output equalizers, automatic opening system for microphones, 8 antilarsen with different algorithm (one for each output), gate and delay.
- M12 v3 is the evolution of M6 meant for those who have high demands in audio and want to get maximum performance in speech intelligibility and sound pressure. When it is required to handle multiple signals and send them to multiple outputs processing delays and equalizers, M12 is an indispensable tool.
- M12 v3 is a tool that allows you to get a good speech intelligibility in any environment where it is installed, increasing the efficiency of the audio system and increasing the SPL.
- M12 v3 is configured at installation time using a PC with proprietary software.
- M12 v3 is supplied in 2U standard rack and provided with a recall presets panel.
- M12 v3 is easy to manage for the final customer.

### TECHNICAL SPECIFICATIONS

- 12 inputs and 8 outputs balanced XLR mic / line.
- 12X8 matrix by pass
- configurable and remotable potentiometers
- parametric equalizers on each input
- 8 antilarsen assignable outputs on dual technology
- 8 noise gate
- 8 delay
- 6 EQ on every output
- 32 configurable presets
- AutoMixer with advanced logic
- Dedicated software
- Compressor
- Phantom
- Gain up to 50 dB input



RP6 PANEL



### GENERAL SPECIFICATIONS

- NUMBER OF BITS ..... 24
- DYNAMICS ..... 96 dB
- INPUT LEVEL ..... -50 dB +50 dB
- IMPEDANCE INPUT ..... 6K Ohm
- OUTPUT LEVEL ..... -60 dB + 6 dB
- INPUT LEVEL MAXIMUM ..... + 50 dB
- OUTPUT IMPEDANCE ..... 100 Ohm
- FREQUENCY RESPONSE ..... 20HZ/20000Hz
- OPERATING TEMPERATURE ..... -5+40° C
- SAMPLING FREQUENCY ..... 42 KHz
- POWER SUPPLY ..... 230V ± 10% -50 Hz
- POWER CONSUMPTION ..... 10 VA
- DIMENSIONS (WxHxD) mm ..... 483X90X200 - 2U standard rack
- WEIGHT ..... 4 KG

### SOFTWARE PROGRAMABLE SPECIFICATIONS

- ANTILARSEN (2 parameters adjustable with double algorithm)
  - PHASE ..... from 1 to 7,5 ms / from 0,1 to 2 Hz
  - FREQUENCY ..... from 0,1 to 2 Hz
- MATRIX BY PASS ..... 6 X 4
- NOISE GATE (3 adjustable parameters) ..... threshold, delay, slope
- DELAY ON EVERY CHANNEL ..... from 0 to 64 mt
- PARAMETRIC FILTERS
- 32 PRESET SELECTABLE BY REMOTE CONTROL
- REVERSE PHASE 180° PROGRAMMABLE ON INPUT AND OUTPUT

The images are purely illustrative and the details can be changed without any warning.

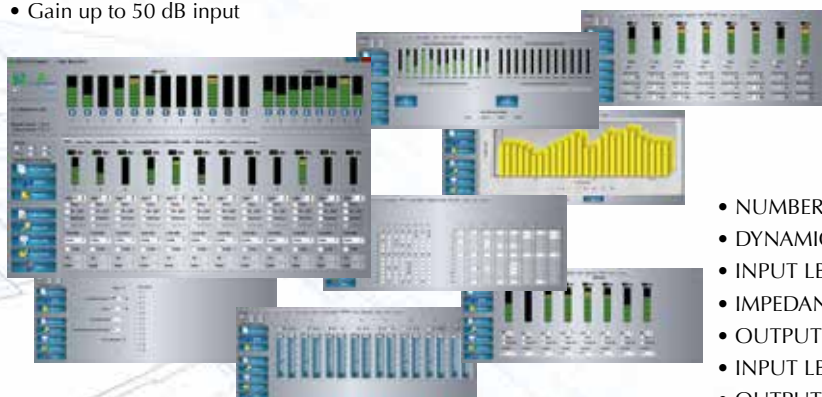

### ACCESSORIES

- **SUPPLIED:**  
RP6 PANEL - PRESET RECALL WITH 6 ITEMS
- **OPTIONAL:**  
M-CONTROL INTERFACE TOUCH





SUPPORT MADE IN ITALY  
BUY OUR PRODUCTS

# AMP 150

Integrated Amplifier

AMP 150 is Fulgor Service amplifier suitable for any installation where it is required to amplify the audio signal and get a clean sound.

AMP 150 is a professional amplifier in class A/B composed by mixer, preamplifier and 150W RMS power amplifier.

AMP 150 is designed, engineered and manufactured in Fulgor Service using all made in Italy components, with high quality standards.

AMP 150 can handle up to 6 mic inputs and 3 line inputs on two outputs, one low frequency signal output and one amplified with output transformer. IN/OUT to connect antilarsen or effects. Dedicated monitor output.

AMP 150 is built with a solid metal structure 2U standard rack 19".



The images are purely illustrative and the details can be changed without any warning.



## TECHNICAL SPECIFICATIONS

### AMP 150

- DESCRIPTION: \_\_\_\_\_ compact amplifier
- TYPE: \_\_\_\_\_ 150 W mono
- RATED MAXIMUM POWER: \_\_\_\_\_ RMS 150W - max 180W
- COOLING: \_\_\_\_\_ air cooling by dissipator
- PROTECTION: \_\_\_\_\_ n. 2 self-test and output short circuit
- PASSBAND (-3 dB): \_\_\_\_\_ 50-20.000 Hz
- MIC INPUTS: \_\_\_\_\_ n° 6 jack XLR 0,8 mV - 22 KOhm
- CD INPUTS: \_\_\_\_\_ n° 2 jack RCA 80 mV - 1 KOhm
- LINE INPUTS: \_\_\_\_\_ n° 2 jack RCA 150 mV - 30 KOhm
- LINE INPUT: \_\_\_\_\_ n° 1 balanced XLR
- OUTPUT (impedance): \_\_\_\_\_ 4 / 8 / 16 Ohm
- VOLT OUTPUTS: \_\_\_\_\_ 50V - 100V
- VOICE FILTER: \_\_\_\_\_ on/off
- UP OUTPUT: \_\_\_\_\_ n° 1 jack mono 6,3 - 775 mV
- FEEDBACK PROCESSOR CONNECTION: \_\_\_\_\_ n° 1 jack stereo 6,3
- MIC CONTROL: \_\_\_\_\_ n°6 - volume (5 fixed - 1 selectable)
- LINE CONTROL: \_\_\_\_\_ n°2 - volume
- MASTER CONTROL: \_\_\_\_\_ n°1 - volume
- TONE CONTROL: \_\_\_\_\_ n. 3 - bass, medium, treble
- PHANTOM CONTROL: \_\_\_\_\_ n. 6 - by micro switch for input
- VAC MAIN: \_\_\_\_\_ 230 V /50 Hz IEC M
- VAC OUT: \_\_\_\_\_ 230 V /50 Hz IEC F
- APPEARANCE: \_\_\_\_\_ 2U standard rack
- DIMENSIONS (WxHxD) mm: \_\_\_\_\_ 483 x 100 x 305
- WEIGHT: \_\_\_\_\_ 15 Kg
- NOTE.: \_\_\_\_\_ specific monitor output with volume

# AMF 120 AMF 200

Automixer with Amplifier

# AMX 103

Automixer without Amplifier

- **AMF 200** and **AMF 120** sare automatic signal mixers with 200W and 120W amplifier respectively provided with output transformer.
- **AMF 200** and **AMF 120** have 10 A.F. input channels and 3 output. An outputs of 200W RMS and 120W RMS respectively. Solve feedback and return of the reverb problems created by the use of numerous microphones in the same environment.
- **AMF 200** and **AMF 120** provide an already amplified clear and intelligible audio, this thanks to the possibility to vary the tone of each input and the opening of the microphones; in fact, on each microphone input you can vary the treble, mid, bass, gate and opening channel.
- **AMF 200** and **AMF 120** are equipped with a set of features suitable to mixing and amplification in all environments, even the larger ones.
- **AMF 200** and **AMF 120** thanks to their technical characteristics are suitable to manage simple audio systems, or to be placed in complex audio systems to amplify small and large structures.



- **AMX 103** has the same characteristics as AMF but is not equipped with amplifier.



## TECHNICAL SPECIFICATIONS

- 6 electronic balanced mic inputs characterized by:
  - Adjustable three-band EQ for each mic channel
  - Two-color LED for channel status indication
  - Channel gain control
  - Adjustable threshold THD
  - 43V phantom power assignable for each mic channel
  - In and Out effects only on the microphones. (antilarson, etc.)
- Connection options: low or high impedance line.
- 1 CD input with tone control
- 1 AUX input with tone control
- 2 Input 150mV
- 1 BF balanced input Line with control ( $\pm 6$  dB)
- General level indicator
- General Master Volume
- 2 balanced outputs with separate volume ( $\pm 6$  dB)
- 1 Aux output
- Components and chassis shielded from radio frequency.
- Possibility of advanced logic functions for multiple applications:
  - Opens only engaged mic channels and attenuates others (with variable attenuation as open channels)
  - LAST-ON: the last activated microphone remains active even when the speaker has finished speaking until a new microphone is activated
  - FILIBUSTER: can be switched on only one microphone at a time
- NOMA: automatic attenuation of open channels at the same time
- Built-in monitor with adjustable volum
- Power supply: 200/240 V AC 50-60 Hz IEC socket
- Dimension (WxHxD in mm): 483 x 140 x 305

## AMF 200/AMF 120/AMX 103 - COMMON CHARACTERISTICS

### AMF 200

- DESCRIPTION \_\_\_\_\_ automatic automixer with amplifier
- AMPLIFIER \_\_\_\_\_ 200 W
- RMS RATED POWER \_\_\_\_\_ RMS 180W - 260W peak at 4 Ohm
- COOLING \_\_\_\_\_ forced air cooling by fan
- PROTECTION \_\_\_\_\_ 2 self-test and output short circuit
- FREQUENCY RESPONSE \_\_\_\_\_ 40 ÷ 20000 Hz -0,5 dB
- S/N RATIO \_\_\_\_\_ > 85 dB
- WEIGHT \_\_\_\_\_ 16,3 Kg

### AMF 120

- DESCRIPTION \_\_\_\_\_ automatic automixer with amplifier
- AMPLIFIER \_\_\_\_\_ 120 W
- RMS RATED POWER \_\_\_\_\_ RMS 120W - 180W peak at 4 Ohm
- COOLING \_\_\_\_\_ air cooling by dissipator
- PROTECTION \_\_\_\_\_ 2 self-test and output short circuit
- FREQUENCY RESPONSE \_\_\_\_\_ 40 ÷ 20000 Hz -0,5 dB
- S/N RATIO \_\_\_\_\_ > 85 dB
- WEIGHT \_\_\_\_\_ 14,8 Kg

### AMX 103

HAS THE SAME CHARACTERISTICS AS AMF BUT IS NOT EQUIPPED WITH AMPLIFIER.

- DESCRIPTION \_\_\_\_\_ automatic automixer
- WEIGHT \_\_\_\_\_ 7,1 Kg

# AMP 60 / MX 71

Amplifier - Mixer



AMP 60 is a professional amplifier with 8 inputs and 2 outputs.

AMP 60 has a robust final in class A/B which produces the power of 60W RMS at 4Ohm and allows it to be used in any audio system, from the simplest to the most complex.

AMP 60 has the ability to handle the bass and treble on each microphone input and a low-cut filter.

AMP 60 is supplied without amplifier too, as pure mixer and it is named MX 71, it has the same characteristics as AMP 60 without amplifying.

AMP 60 and MX 71 are supplied in 1U standard rack 19" and their weight is 2kg (MX 71) and 4kg (AMP 60). 220V power supply with IEC connector.

AMP 60 and MX 71 have the quality to make the sound clean and intelligible.



## TECHNICAL SPECIFICATIONS

### AMP 60 - MX 71

- OUTPUT POWER: (AMP60 only) \_\_\_\_\_ 68 W, 4 Ohm
- FREQUENCY RESPONSE: \_\_\_\_\_ 20 Hz - 20 KHz (+0, -3 dB)
- HARMONIC DISTORSION: \_\_\_\_\_ THD < 0,1% a +20 dB output Master
- SENS. MICROPHONE INPUTS: \_\_\_\_\_ -60 dB - 2 KOhm
- SENS. AUX INPUTS - 1 BALANCED: \_\_\_\_\_ -20 dB - 50 KOhm (internal jumper on line position)
- SENS. AUX INPUTS - 1 BALANCED: \_\_\_\_\_ -56 dB - 2 KOhm (internal jumper on mic position)
- SENS. AUX INPUTS - 2 RCA: \_\_\_\_\_ -20 dB - 20 KOhm
- BASS CONTROL: \_\_\_\_\_ on all channels at 100 Hz  $\pm$ 14 dB - F.T.  $\pm$ 3 dB 500 Hz
- TREBLE CONTROL: \_\_\_\_\_ on all channels at 10 KHz  $\pm$ 14 dB - F.T.  $\pm$ 3 dB 1,7 KHz
- LOW CUT FILTER: \_\_\_\_\_ -3 dB @ 700 Hz
- OUTPUT REC OUT: \_\_\_\_\_ 0 dB - 6 KOhm
- BALANCED OUTPUT SIGNAL: \_\_\_\_\_ +20 dB max (unbalanced without signal loss)
- MIC INPUT: \_\_\_\_\_ n° 6 jack XLR phantom selectable
- FEEDBACK PROCESSOR CONNECTION: \_\_\_\_\_ 1 stereo jack IN/OUT
- AUX 1 INPUT: \_\_\_\_\_ 1 balanced XLR
- AUX 2 INPUT: \_\_\_\_\_ 2 RCA
- REC OUT: \_\_\_\_\_ 2 RCA
- LINE OUT: \_\_\_\_\_ 1 balanced XLR
- LOUDSPEAKERS OUTPUT: (only AMP60) \_\_\_\_\_ 1 two-way terminal
- VAC INPUT: \_\_\_\_\_ power fuse
- VOLUME ADJUSTMENTS : \_\_\_\_\_ 8 (one per input)
- MASTER VOLUME: \_\_\_\_\_ 1
- VU METER: \_\_\_\_\_ 4 led (-40, -20, 0, +10 dB)
- LED INDICATOR: \_\_\_\_\_ 1 protection (red) / operating (green)
- POWER SUPPLY: \_\_\_\_\_ 220/230 V ca /max power 110 VA (AMP60) - max power 10 VA (MX7 1)
- DIMENSIONS (WxHxD) mm: \_\_\_\_\_ 483 x 45 x 305
- WEIGHT: \_\_\_\_\_ from 2 to 4 Kg (amplified)
- PHANTOM POWER ACTIVATED BY DIPSWITCH
- LOW-CUT FILTER ACTIVATED BY DIPSWITCH
- PREARRANGEMENT FOR BALANCED INPUT AUX1 LINE OR MIC



**UP 2x120** is an amplifier for specific applications in matters of sound, wherever it is required quality, robustness and reliability.

**UP 2x120** includes 2x120W RMS amplifier, totally separated from each other. Suitable for multi-room audio system.

**UP 2x120** is designed with external potentiometers for each input with which you can adjust the volume of each individual channel.

**UP 2x120** has audio outputs 4Ohm-8Ohm and 50V-100V.

**UP 2x120** has electronic circuitry with characteristics of quality and safety. Metal framing is suitable to be on plane and is designed for 19" standard rack (2U rack) mounting.



**DPA 6** digital amplifier is an amplifier for specific applications in matters of sound, wherever it is required quality, robustness and reliability.

**DPA 6** includes 6 class D 150W RMS amplifier, totally separated from each other. Suitable for multi-room system or to drive Directivity system.

**DPA 6** has a cooling system with fan air thermostated and it is fully provided with protection against output shortcircuits.

**DPA 6** designed for connection of an external potentiometer for each input with which you can adjust the volume of each channel.

**DPA 6** has 6 outputs provided for connection to constant impedance lines (4Ohm). An external line transformer is provided as optional, TR150 (one for each channel required) with which it is possible to adapt the impedance 4Ohm, 8Ohm, 16Ohm and 50V, 70V, 100V.

**DPA 6** has electronic circuitry with details of quality and safety. Metal framing is suitable to be on the plane and is designed for mounting in 19" rack (2U).

### TECHNICAL SPECIFICATIONS

#### DPA 6

- DESCRIPTION: \_\_\_\_\_ multi-channel amplifier
- TYPE: \_\_\_\_\_ 6 x 150 W RMS channels
- RATED MAXIMUM POWER: \_\_\_\_\_ RMS 6x150W - max 6x180W
- COOLING: \_\_ air cooling by dissipater + thermostatically controlled fan
- PROTECTION: \_\_\_\_\_ output short circuit + on/off antibump
- PASSBAND: \_\_\_\_\_ 20-22.000 Hz ± 2 dB
- AF INPUTS: \_\_\_\_\_ n° 6 XLR 0,8 mV - 22 KOhm
- OHM OUTPUTS: \_\_\_\_\_ 4 Ohm
- OPTIONAL OUTPUTS TR 150: \_\_ 4ohm-8ohm-16ohm and 50V-70V-100V
- VAC MAIN: \_\_\_\_\_ 230V a.c./50 Hz IEC M
- VAC OUT: \_\_\_\_\_ 230V a.c./50 Hz IEC F
- EXTERNAL VOLUME CONTROL: \_\_\_\_\_ provided for internal connection
- APPEARANCE: \_\_\_\_\_ 2U standard rack
- DIMENSIONS (WxHxD) mm: \_\_\_\_\_ 483 x 100 x 300
- WEIGHT: \_\_\_\_\_ 10 Kg



#### TR 150

- INPUT: \_\_\_\_\_ 4 Ohm
- OUTPUT (Ohm): \_\_\_\_\_ 4, 8, 16
- OUTPUT (Volt): \_\_\_\_\_ 50, 70, 100
- RATED MAXIMUM POWER: \_\_\_\_\_ 180 Watt RMS



TR150



### TECHNICAL SPECIFICATIONS

#### UP 2 X 120

- DESCRIPTION: \_\_\_\_\_ multi-channel amplifier
- RATED MAXIMUM POWER: \_\_\_\_\_ 2 x 120 W
- PEAK POWER: \_\_\_\_\_ 2 x 160 W
- PASSBAND: \_\_\_\_\_ 20 - 20.000 Hz
- DISTORTION AT RATED POWER AT 1 KHZ: \_\_\_\_\_ < 1%
- CONSTANT IMPEDANCE: \_\_\_\_\_ 4 - 8 Ohm
- VOLTAGE: \_\_\_\_\_ 50 - 100 V
- S/N RATIO: \_\_\_\_\_ > 90 dB
- AF INPUTS : \_\_\_\_\_ n° 2 XLR 0,8 mV - 22 KOhm
- VAC MAIN: \_\_\_\_\_ 230V a.c./50 Hz IEC M
- VOLUME CONTROL: \_\_\_\_\_ frontal potentiometers
- COOLING: \_\_\_\_\_ air cooling by dissipator
- CONSUMPTION: \_\_\_\_\_ 440 VA
- DIMENSIONS (WxHxD) mm: \_\_\_\_\_ 483 x 100 x 256
- WEIGHT: \_\_\_\_\_ 12 Kg

The images are purely illustrative and the details can be changed without any warning.

SUPPORT MADE IN ITALY  
BUY OUR PRODUCTS

DSP  
DIGITAL SIGNAL PROCESSING

X5 plus<sup>3</sup>

# Digital Processor with DSP



X5 plus<sup>3</sup>

Multifunction Digital processor with DSP, encloses 5 devices indispensable to achieve high performance in reverberant environments.

Fulgor Service digital technology enriches its catalog with the third generation of a revolutionary device, that exploiting the DSP potential performs many features that have become fundamental and indispensable in any audio installation. The main features can be summarized in 5 essential points:

1. ANTILARSEN function with double algorithm: the classical frequency shift and the innovative technology in phase modulation which allows to have greater cleaning of the treated signal, and a less evident interpolation with audio signals having many harmonics (typically the sound of an organ)
2. EQ function with 10 fully configurable filters (PA, PB, PEAKING, FLAT), you get a proper tone in reverberant or acoustically difficult environments.
3. DELAY function on output with scale in meters for an easy adjustment of the delay (configurable between 0 and 25 meters) useful for the re-timing of multiple lines of speakers or virtually Keep away microphone from the speakers.
4. NOISE GATE function on input and output with 3 controls (LEVEL, SUPPORTING, DECAy).
5. PRESET function with an user interface provided with 3 momentary buttons, equipped with the POWER UP function set on Preset 1; possibility to change any parameters of the machine re-calling a preset.

## TECHNICAL SPECIFICATIONS



DSP  
DIGITAL SIGNAL PROCESSING

## GENERAL SPECIFICATIONS

- NUMBER OF BITS ..... 24
- SAMPLING FREQUENCY ..... 42 KHz
- DYNAMICS ..... 96 dB
- INPUT LEVEL ..... -20 dB $\mu$  +8 dB $\mu$
- IMPEDANCE INPUT ..... 6K Ohm
- OUTPUT LEVEL ..... 0 dB (+ 10 dB $\mu$  max)
- OUTPUT IMPEDANCE ..... 100 Ohm
- FREQUENCY RESPONSE ..... 20HZ/20KHz -1dB
- OPERATING TEMPERATURE ..... -5+40° C
- POWER SUPPLY ..... 230V  $\pm$  10% -50 Hz
- POWER CONSUMPTION ..... 10 VA
- DIMENSIONS (WxHxD) mm ..... 483X45X200 - 1U standard rack
- WEIGHT ..... 3,5 KG

## SOFTWARE PROGRAMMABLE

- OUTPUT LEVEL ..... -12 + 6 dB
- INPUT LEVEL .....  $\pm$  12 dB
- ANTILARSEN (2 adjustable parameters with double algorithm)
  - FREQUENCY SHIFT ..... da 0,1 a 50 Hz
  - DELAY: ..... da 0 a 10 ms
- NOISE GATE (3 adjustable parameters) \_ threshold, operating delay, decade
- DELAY: ..... max 25 mt
- PARAMETRIC EQ FILTERS: ..... 10 totally adjustable
- PRESET: ..... 3, selectable by keys on front panel
- REVERSAL OF PHASE: ..... 180° programmable

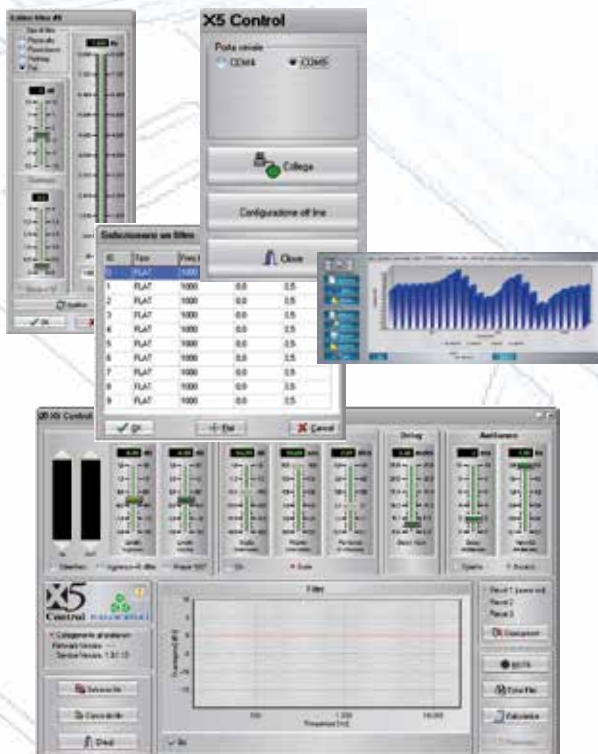

The images are purely illustrative and the details can be changed without any warning.





# MDF 82

## Power Strip



- **MDF 82** is a power strip 220V with 8 IEC filtered by RF and VDR filters to suppress impulsive disturbances from the mains. The management system of the power supplies is of fundamental importance when you have to turn on multiple devices at same time.

- **MDF 82** is manufactured according 19" standard rack and is equipped with an integrate anti-pump circuit to eliminate the annoying "PUMP" switching on and off of some amplification system.
- **MDF 82** is recommended for its ease of use and its absolute security. In case of doubts on the power supply system it is necessary to use it, otherwise failures in the system itself may occur.
- **MDF 82** brilliantly solves every need of the power management.



### TECHNICAL SPECIFICATIONS

- DESCRIPTION: \_\_\_\_\_ 220 V strip
- AC OUTPUTS: \_\_\_\_\_ 8 x 230 V
- ANTI-PUMP CIRCUIT: \_\_\_\_\_ insertable
- APPEARANCE: \_\_\_\_\_ 1U standard rack
- PROTECTION: \_\_\_\_\_ RF - VDR
- DIMENSIONS (WxHxD) mm: \_\_\_\_\_ 483 x 45 x 310 mm
- VAC MAIN: \_\_\_\_\_ 230 V - 50 Hz
- WEIGHT: \_\_\_\_\_ 3,5 Kg
- VAC OUT: \_\_\_\_\_ 230 V - 50 Hz



# FB 5000

## Antilarsen with Noise Gate



- **FB 5000** is a professional processor that eliminates "Larsen effect" preventing your sound and voice system "whistles" and enhancing in the meantime the power and ensuring the cleanliness and intelligibility of the voice.
- **FB 5000** is designed and manufactured for the use in all environments, in particularly in those acoustically difficult, of any size.
- **FB 5000** is a professional device essential in any installation and can be adapted to most of the systems, new or existing.
- **FB 5000** is an antilarsen processor with frequency shift, its installation is recommended in any voice amplification system.
- **FB 5000** is specifically designed for the elimination of the electroacoustic reaction between speakers and microphones.
- **FB 5000** also incorporates a noise gate to suppress background noise during breaks of the signal, this can be inserted when you want to drastically reduce the background noise of the microphones during breaks. The intervention threshold is adjustable.



- **FB 5000** has an automatic exchange system between unbalanced and balanced IN-OUT to connect with professional amplification systems (XLR).
- **FB 5000** has an automatic exchange system between unbalanced and balanced IN-OUT to connect with professional amplification systems (XLR).



### TECHNICAL SPECIFICATIONS

- INPUT LEVEL: \_\_\_\_\_ 0 dBμ(+10 dBμ max)
- FREQUENCY RESPONSE: \_\_\_\_\_ 30 Hz / 20 Hz -1 dB
- INPUT IMPEDANCE: \_\_\_\_\_ 100 KOhm
- DISTORTION: \_\_\_\_\_ < 0,1%
- OUTPUT LEVEL: \_\_\_\_\_ 0 dB (+ 10 dBμ max)
- BACKGROUND NOISE: \_\_\_\_\_ (w/o NG) -90 dBA rif. 0 dB@ 1 KHz
- OUTPUT IMPEDANCE: \_\_\_\_\_ 220 Ohm
- VAC MAIN: \_\_\_\_\_ 230 V - 50 Hz IEC M
- SHIFTING FREQUENCY: \_\_\_\_\_ 1 - 10 Hz
- POWER CONSUMPTION: \_\_\_\_\_ 5 VA
- SHIFTING: \_\_\_\_\_ increasingly or decreasingly
- DIMENSIONS (WxHxD) mm: \_\_\_\_\_ 483 x 45 x 310
- NOISE GATE: \_ adjustable threshold with rapid intervention and soft start
- WEIGHT: \_\_\_\_\_ 3,5 Kg

# Il Campanile

Electronic Bell Programmer

# CHORUS

Digital Audio Reproducer



- **IL CAMPANILE** is an electronic reproducer of the sound of 50 bells, to be played swinging or pealing, with high fidelity sound, and allows you to use up to 16 outputs for the control of real bells (using the optional device PD8/S)..

- **IL CAMPANILE** is equipped with a graphic display that greatly simplifies user's interface making the programming faster and more direct.

- **IL CAMPANILE** has also a manual section for the immediate start of 6 bells swinging or pealing and a section for the direct start of 7 programmed bells, with a remote control too.

- Graphic display with 8 lines and 40 characters each.
- Manual section for the command of 6 swinging and pealing bells.
- Time synchronization by DCF77 signal or GPS.
- Auxiliary input to amplify signals coming from recorders, compact, mixer outputs (record-players, microphones).
- Output for the command of real bells ( up to 16 ) with power actuator PD8 / S.
- Direct section for the immediate start of 4 melodies (also by radio-control).
- Connection to Standard Midi Interface for the composition and play of melodies.
- Control and automatic adjusting of tower clock's with power actuator PD8/S.
- Managing of data, melodies and programming by personal computer or telephone.
- Possibility to upload and download data on/from another IL CAMPANILE, using a telephone too.
- Tones and volume control.
- Monitor's volume control.
- More than 70 melodies in the archive.
- Memory capacity of 1000 melodies.
- Possibility of composing and memorizing on the spot all kinds of melodies with swinging and pealing bells.
- Automatic fading volume control, both overall and per single bell.
- Possibility of volume reduction during nighttime.
- Possibility to transpose the chromatic scale.
- Automatic and differentiated programming according to the different liturgical periods of the year (Summer and Winter, the month of May, etc.).
- Programming of fixed feasts (Christmas, Immaculate Conception, Assumption Day, etc.) and automatic calculation of movable feasts (Easter, first Friday of the month, etc.).
- Automatic daylight savings time.
- Automatic erasing of programs not to be repeated.
- Time-striker in 22 different forms.
- Data retaining without mains supply for more than 30 days.
- Saving data on external memory card.

- **CHORUS** is an audio reproducer of music pieces and voice, one at a time or grouped, with stereo high fidelity performances without using cd, hard disk o magnetic tape.

- **CHORUS** has an SD memory card that makes the device high reliable, easy to use and with rapid feedback.

- The music or voice pieces are reproduced by the manual keyboard present on the front panel or by the optional remote control, immediately or at fixed time, by single piece or in groups or concerts.

- **CHORUS** is supplied with about 633 songs, most of which in dual mono format, then the voice is separated from the music to get a better authenticity of chants.

- Reproduction of music/voice pieces for a total capacity of 16 hours (optional longer time according to SD memory's capacity).

- Possibility of grouping in 20 different groups (concerts) with 59 pieces: a concert execution involves sequential playback of all tracks that compose it.

- Possibility of grouping in 20 different groups (concerts) with 59 pieces: activating a group allows to control the single playing of the songs manually or with remote control: the choice of the song to play can be both in sequence and random.

- Possibility to activate timed with the definition of the minute, the execution of any song or concert in memory.

- Stereo or mono audio outputs on one of two channels and reverse of the same

- Alphanumeric and graphic display of 2 lines with 20 characters each.

- Keyboard with 19 buttons for manual use.

- Remote control for starting and stopping of pieces, groups or concerts, with volume regulation, general of for single channel.

- Mains 230V~ 20VAC.

- Permanent data retaining.

- Uploading of pieces by personal computer directly into the SD card (external).

## TECHNICAL SPECIFICATIONS

- AUX STEREO OUTPUT: \_\_\_\_\_ max 4 Vpp su 10 kOhm
- BNC ANTENNA INPUT OF WIRELESS RECEIVER: \_\_\_\_\_ 433 MHz
- DIMENSIONS (WxHxD) mm: \_\_\_\_\_ 483 x 100 x 205
- WEIGHT: \_\_\_\_\_ 5,0 Kg
- ENVIRONMENTAL CONDITION FROM: \_\_\_\_\_ da 0°C a 45°C
- MAINS POWER SUPPLY: \_\_\_\_\_ 230 V a.c. - 50Hz
- AVERAGE ABSORPTION : \_\_\_\_\_ <20VA not working

## SPK 360

Outdoor speaker, dispersion 360°, 400W 4Ohm, small in size, suitable to reproduce the sound of bells, warnings and announcements, thanks to his good sound quality. It comes complete with brackets for both wall and ground mounting.

Diameter 43cm, Depth without pole 15cm, Weight 14 Kg.



## TECHNICAL SPECIFICATIONS

- CPU: \_\_\_\_\_ 80180 (12MHz)
- RAM MEMORY: \_\_\_\_\_ Max 131 Kbyte
- EPROM MEMORY: \_\_\_\_\_ Max 131 Kbyte
- INTERFACE: \_\_\_\_\_ n.1 RS232 serial + n.1 AUX (optional) + n.1 Midi
- OUTPUT POWER: \_\_\_\_\_ 150W - 200W - 300W (RMS)
- DIMENSIONS WxHxD) mm: \_\_\_\_\_ 483 x 180 x 215
- WEIGHT: \_\_\_\_\_ Kg 11 o 14 (it depends on model/power)
- POWER SUPPLY: \_\_\_\_\_ mains 230V~ -20%+10% 50Hz ±5%
- AVERAGE ABSORPTION: \_\_\_\_\_ 10VA not working
- MAX.ABSORPTION: (according to the model): 250VA (150W), 350VA (200W), 500VA (300W)
- BUFFER BATTERY : \_\_\_\_\_ Ni-Cd 3,6V 65m

# Microphones

Professional, Dynamic, Gooseneck, Sleek



## FS 324

• **FS 324** is a miniaturized desktop microphone with high sensitivity; in fact, thanks to its Hypercardioid condenser dedicated capsule is able to have an optimal performance in all environmental conditions. The compact design and the short length (only 24 cm) make it easy to locate on the altars or tables conference, where small encumbrance is required. It's equipped with 3m microphone cable with XLR connector.



- CAPSULE \_\_\_\_\_ hypercardioid condenser
- FREQUENCY \_\_\_\_\_ 30 Hz - 20.000 Hz
- SENSITIVITY \_\_\_\_\_ -54 dB ±3 dB
- IMPEDANCE \_\_\_\_\_ 250 Ohm ±30%
- PHANTOM \_\_\_\_\_ 12 V - 48 V DC
- TOTAL LENGTH \_\_\_\_\_ 240 mm
- COLOUR \_\_\_\_\_ white

## FS 933

• High sensitivity table microphone in white colour, long shot hyper-cardioid capsule, makes the voice clear and intelligible. Designed for reinforcement of high quality sound in an ultra-compact design. The low-profile element of the microphone offers one narrow Microline® polar pattern with angle of acceptance of 90°. Suitable for all types of table or Altar, thanks to its minimalist shape it is easy to install in any environment. White colour, white cord.



- CAPSULE \_\_\_\_\_ HYPER-CARDIOD
- FREQUENCY \_\_\_\_\_ 30HZ - 20.000HZ
- SENSITIVITY \_\_\_\_\_ -35DB +/- 3DB
- IMPEDANCE \_\_\_\_\_ 250OHM
- PHANTOM \_\_\_\_\_ 11V - 52V DC
- TOTAL LENGTH \_\_\_\_\_ 92MM

## FS 333

• Gooseneck microphone **FS 333** is a high-performance miniature microphone, thanks to the specific microphone capsule it highlights voice's tones making it more clear and intelligible. **FS 333** has a unidirectional range, provided with a windscreen for a further protection from environmental noises and those produced by breath.



- CAPSULE \_\_\_\_\_ cardioid condenser
- FREQUENCY \_\_\_\_\_ 30 Hz - 18.000 Hz
- SENSITIVITY \_\_\_\_\_ -65 dB ±3 dB
- IMPEDANCE \_\_\_\_\_ 250 Ohm ±30%
- PHANTOM \_\_\_\_\_ 5 V - 52 V DC
- TOTAL LENGTH \_\_\_\_\_ 445 mm

## FS 935

• Gooseneck miniaturized microphone, hypercardioid condenser capsule, precise, it makes the voice clear and intelligible. Professional microphone which has the option to change the microphone capsule and decrease the length from 31cm to 19cm. **FS 935** is suitable to be installed on altars or pulpits and finds an excellent employment also to capture groups or choirs of people, in fact, thanks to the longer microphone capsule it gets to receive over 2 meters.



- CAPSULE \_\_\_\_\_ unidirectional hypercardioid condenser
- FREQUENCY \_\_\_\_\_ 30 Hz - 20.000 Hz
- SENSITIVITY \_\_\_\_\_ -35 dB ±3 dB
- IMPEDANCE \_\_\_\_\_ 250 Ohm ±30%
- PHANTOM \_\_\_\_\_ 11 V - 52 V DC
- TOTAL LENGTH \_\_\_\_\_ 310 mm in standard version

## MD 100

• **MD 100** is a traditional handheld microphone, dynamic, cardioid, black coloured. It's a sturdy product, with a very high acoustic performance and the voice is faithfully reproduced: perfect for soloist and/or spokesmen. **MD 100** is equipped with built-in ON/OFF switch. It's packaged in a box containing a microphone extension with XLRM/XLRF 8m long and an holder to install it on a stand and/or a base.



- CAPSULE \_\_\_\_\_ cardioid
- FREQUENCY \_\_\_\_\_ 50 Hz - 15.000 Hz
- SENSITIVITY \_\_\_\_\_ -72 dB ±3 dB
- IMPEDANCE \_\_\_\_\_ 600 Ohm
- TOTAL LENGTH \_\_\_\_\_ 52,8 X 177 mm

## FS 51 / FS 901

• Sleek microphones, panoramic, white coloured. Practical and invisible on the altar, they have an excellent sensitivity that allows you to capture the voice also from 1 meter distance. Fulgor Service proposes two sizes small for small structures that are not reverberant and medium to large altars and concelebrations.



- **FS 901**
- CAPSULE \_\_\_\_\_ cardioid condenser
- FREQUENCY \_\_\_\_\_ 50 Hz - 18.000 Hz
- SENSITIVITY \_\_\_\_\_ -68 dB ±3 dB (@ 1KHz)
- IMPEDANCE \_\_\_\_\_ 250 Ohm ±30%

- **FS 51**
- CAPSULE \_\_\_\_\_ cardioid condenser
- FREQUENCY \_\_\_\_\_ 30 Hz - 20.000 Hz
- SENSITIVITY \_\_\_\_\_ -34 dB
- IMPEDANCE \_\_\_\_\_ 200 Ohm

## FS 630

• Headset microphone for internal use **FS 630** is a multifunctional product, for all those who need high quality of voice's sound and hands free. The skin colour appearance makes it barely visible. Its unidirectional condenser capsule produces a better quality of voice and sound isolation for effective feedback control, minimizes environmental noises and those resulting from handling a microphone, deletes all background noises.



- CAPSULE \_\_\_\_\_ cardioid condenser
- FREQUENCY \_\_\_\_\_ 200 Hz - 18.000 Hz
- SENSITIVITY \_\_\_\_\_ -70 dB ±3 dB
- IMPEDANCE \_\_\_\_\_ 1500 Ohm ±30%
- CAPSULE DIAMETER \_\_\_\_\_ 5 mm

## FS 470

• Foulard microphone **FS 470** is a multifunctional, dynamic and contemporary-designed product. Its smooth, ergonomically designed and flexible gooseneck has been projected to suit different persons and it wraps easily around the neck and can be worn with the mic head either on the left or right position. Thanks to its cardioid capsule it gets excellent acoustic characteristics; its compact design is perfect to use audio system outside, for procession, shows, entertainment and so on, for all who require vocal and sound high quality in a hands-free application.



- CAPSULE \_\_\_\_\_ cardioid
- FREQUENCY \_\_\_\_\_ 100 Hz - 18.000 Hz
- SENSITIVITY \_\_\_\_\_ -84 dB ±3 dB
- IMPEDANCE \_\_\_\_\_ 600 Ohm ±30% (@ 1 KHz)
- LENGTH \_\_\_\_\_ 530 mm

## FS 300

• Shotgun microphone. **FS 300** is a microphone designed to amplify choruses, thanks to its polarized condenser capsule, manages to capture the voice from considerable distances, made of aluminum, is provided with stand support and XLR connector with ON/OFF switch.



- CAPSULE \_\_\_\_\_ gradient condenser
- FREQUENCY \_\_\_\_\_ 30 Hz - 20.000 Hz
- SENSITIVITY \_\_\_\_\_ -36 dB ±3 dB
- IMPEDANCE \_\_\_\_\_ 200 Ohm
- PHANTOM \_\_\_\_\_ 11 V - 52 V DC
- TOTAL LENGTH \_\_\_\_\_ 330 mm



# Coach

## Portable Amplifier



**COACH** is a portable amplifier, very lightweight (only 1.5 kgs), with rechargeable batteries (6 hours duration), professional UHF wireless microphone PLL 16-channel, USB port with display and keyboard management tracks, control tone, alarm, wired dynamic microphone. Pull-out handle and strap transport. This product is very flexible, given the minimum size can be used both indoors and outdoors.

### TECHNICAL SPECIFICATIONS

- OUTPUT POWER: \_\_\_\_\_ 40W/25W (RMS) 4 Ohm load
- SPEAKER: \_\_\_\_\_ 4"
- T.H.D.: \_\_\_\_\_ < 0,5%
- AUDIO INPUT: \_\_\_\_\_ Mic, AUX, USB 2.0
- AUDIO OUTPUT: \_\_\_\_\_ AUX
- POWER SUPPLY: \_\_\_\_\_ 20V DC 2,5A
- RECHARGEABLE BATTERY: \_\_\_\_\_ 14,8B / 2,7Ah (Lithium)



- DURATION: \_\_\_\_\_ about 5-6 hours (music), 10-12 hours (speech)
- CHARGING TIME: \_\_\_\_\_ about 4 hours
- DIMENSIONI (WxHxD in mm): \_\_\_\_\_ 156x156x205
- WEIGHT: \_\_\_\_\_ 1,6 Kg
- FREQUENCY RESPONSE: \_\_\_\_\_ 50Hz - 20KHz ± 3 dB
- ANTENNA: \_\_\_\_\_ built in



# DB 2200

## Music Trainer

### Portable Amplified System



DB 2200 back



**DB 2200** is a compact box system built entirely in Italy, with its 200 watts RMS allows to sonorize big spaces, both indoors and outdoors. Very practical use, it is equipped with rechargeable batteries (6 hours duration), MP3, CD, USB, SD card, Wireless microphone professional, P 100 or Bodypack with headset, mixer with inputs and outputs.



CD player

### TECHNICAL SPECIFICATIONS

- MUSIC POWER: \_\_\_\_\_ 200 Watt
- TWO-WAY SPEAKER: \_\_\_\_\_ woofer 11" / dynamic tweeter
- MIC INPUT SENSITIVITY: \_\_\_\_\_ 2,5 mV (-50 dB)
- AUX INPUT SENSITIVITY: \_\_\_\_\_ 150 mV (-8 dB)
- AMPLIFIED SPEAKER AUX OUT: \_\_\_\_\_ 1 V / 2 KOhm
- ACOUSTIC SPEAKER OUT (JACK): \_\_\_\_\_ 8 Ohm amplified
- VOLUME CONTROLS: \_\_\_\_\_ master, treble, bass, wireless microphone, mic, AUX
- POWER INPUT : \_\_\_\_\_ 200/240 VAC - 120VA
- INTERNAL POWER SUPPLY : \_\_\_\_\_ 2x12 V DC 5,7 Ah
- DIMENSIONS (WxHxD in mm): \_\_\_\_\_ 540 x 410 x 330
- WEIGHT: \_\_\_\_\_ about 18 Kg





## SPK360

### Outdoor Speaker

Outdoor speaker, dispersion 360°, 400W 4Ohm, small in size, suitable to reproduce the sound of bells, warnings and announcements, thanks to his good sound quality. It comes complete with brackets for both wall and ground mounting.

Diameter 43cm, Depth without pole 15cm, Weight 14 Kg.

## R30T

### Compact Horn-Loaded Speaker

R30T is an horn-loaded speaker made of special Polypropylene, resistant to water and UV rays, full range.

Designed for quality sound reinforcement at medium and long distances for both voice or music for outdoor or large environments, such as industrial halls, streets, stadiums, military environments, etc. etc.

R30T is equipped with steel front protection, the bracket is included in the package; both bracket and diffuser are gray, weight 11kg.

- Frequency response 80Hz-18kHz  $\pm$ 3dB; • Drivers 1x8"/2" voice coil LF - 1x1"/1.4" voice coil HF; • Input voltage 100V or 8 $\Omega$ ; • Power 37.5W/75W/150W @ 100V - 200W @ 8 $\Omega$ ; • Sensitivity 96dB 1W/1mt; • Max SPL 117dB continuous - 123dB peak; • Impedance 8 $\Omega$  nominal; • Dispersion (-6dB) 100°x100°; • Crossover 2.5kHz passive; • Dimensions 300x320x334mm (WxHxD); • Weight 11kg; • Colore Grey.



## DP103-T

### 2 Way Wall Speaker

DP103-T is a wall speaker with an elegant ABS box and 100 Volt transformer. You can select different power levels or 8  $\Omega$  connection through the proper switch. Suitable for voice and music, designed for both indoor and outdoor use always providing a linear response.

It finds good use in installations in small-medium conference rooms, small-medium multimedia rooms, cruise ships, classrooms, swimming pools, industrial

areas and amusement parks.

- Output Power 45W @ 8 Ohm; Frequency response 90Hz - 20KHz  $\pm$  3dB; Woofer 6,5" - Tweeter 1"; Sensitivity 89 dB (1W/1m); Audio output AUX; Power supply Trasn. 32/16/8/4 Watt; Dimensions mm (WxHxD) 288x216x180; Color white.

## MP16

### Sound projector

MP16 is an ABS UVproof sound projector water resistant with IP56 protection.

- Dual cone coated woofer 5,5" - 8 ohms ;
- Power 16W @ 100V with 3 selectable possibilities (16-10-5W, Impedance 0,625-1-2Kohms);
- Dispersion 160°;
- Response 100-18KHz, SPL 1w1mt.95-max. 107dB;
- Dimensions Diam.138, Depth 200mm;
- Cable lenght 40cm., stainless steel bracket included; Weight 1,35Kg; Color Light Gray.



## Subslim

Ultra-flat passive subwoofer for wall, floor or ceiling installation, in combination with MASK2.

- 6.5 HD double reel woofer 2 x 8 ohms, Power 2 x 120W;
- Response from 50Hz to 200Hz (50-20Khz input for sat), internal stereo crossover with amplifier

input and outputs to the sat; • Sens.85dB 1w1mt .; • Measures 420 x 470 x 120mm, bracket for wall mounting included; • White color; • Weight 8Kg.

## MH 6300

### Loaded Horn Speaker

MH 6300 is a 2-way horn-loaded speaker in ABS, gray color, water resistant (IP 66), RMS 60W, 100V or 8 Ohm. Complete support bracket.

Dimensions (WxHxD in mm): 370 x 270 x 305



## TU108

### High Efficiency Horn Speaker

The horn speaker high efficiency TU 108 has been designed for professional use, even heavy and demanding. Thanks to its powerful driver and its structure, it has a sound acoustic pressure of 129dB; the very small total size allows an easy installation.

Body in ABS, driver in ferrite, steel bracket, IP 66: all this makes TU 108 suitable for installation on civil vehicles, industrial vehicles and rescue/emergency vehicles, both terrestrial and marine.

TU 108 is suitable for sonorizing large environments, also very noisy; it can be used to launch "safety messages", as multitone siren or to boost voice signals.

- Power 100W @ 8 $\Omega$ ;
- Dimensions (WxHxD) mm 205X154X133



## DS 178T

### 2 Way Ceiling Speaker

DS 178T is a ceiling speaker with a 100 Volt transformer. You can select different power levels or 8  $\Omega$  connection through the proper switch.

Suitable for voice and music, designed specifically for false ceilings, it is invisible but always provides a linear response.

It finds good use in installations in small-medium conference rooms, small-medium multimedia rooms, cruise ships, classrooms, swimming pools, industrial areas and amusement parks.

- Power 32W @ 8 $\Omega$ ;
- Dimensions ( $\varnothing$ xD) mm 203X109



# LOOP

Magnetic induction system

by **univox**

Among the numerous sectors in which PA system is applied, Fulgor Service has specialized in "LOOP", a magnetic induction system that makes communication accessible to people with hearing loss and hearing aid wearers. The inductive LOOP allows the automatic connection of the hearing aid with an audio system, allowing, in the enabled area, a perfect listening to those who are talking. The installable systems are many, from the simplest ones, to be installed at home, to the most complicated and professional for very large areas, in the open field too. With the development of these technologies, we are currently coming to extend the use of this system also in demarcated areas: taxis, post offices, office desks, etc. Fulgor Service boasts many years of experience in designing, manufacturing and installation of these systems and currently works in synergy with one of the largest companies worldwide operating in the production of these

devices, thus being able to offer appropriate solutions for each customer's request, satisfying their needs. You can contact us at the numbers you find on this brochure. One of our sales staff will be pleased to visit you at your place to offer you a solution.

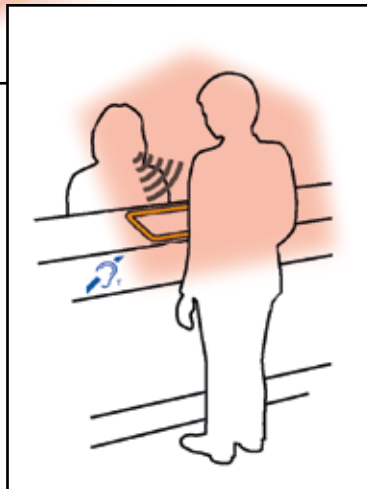
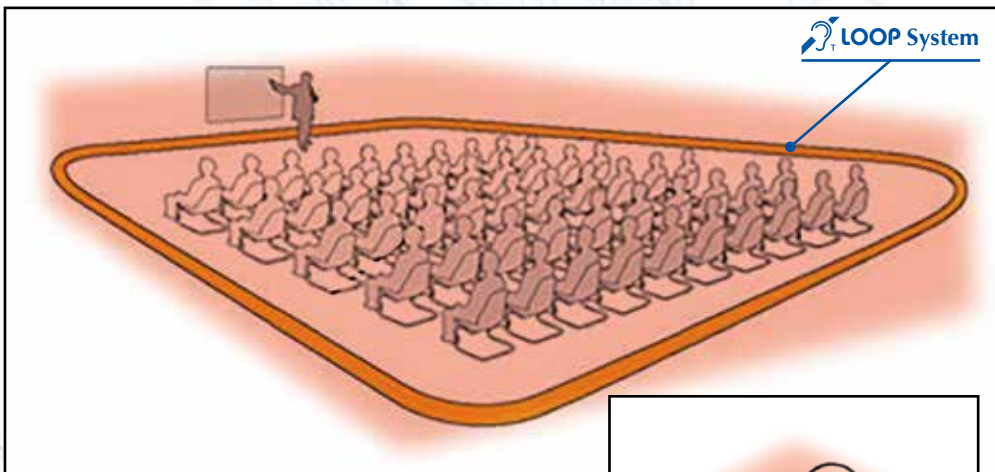

Museums



Cinema



Offices



Reception



Hotel



Bank



Hospitals



Taxi



University



Supermarket



Churches



Boats



Schools



Info Point



Multipurpose Rooms



Tour-Guide

**Texts approved by the Parliament - Edition 03/09/2003**  
**Rights and dignity of the people with disabilities A5-0270/2003**

**European Parliament** resolution about Communication from the Commission "Towards a United Nations instrument legally binding for the promotion and protection of rights and the dignity of people with disability" - COM (2003) 16 -2003/2100 (INI)

**Excerpt Article 19**

(...) asks the UN Member States to ensure that in the future convention will be specified at least the following disability rights:

- h) access to culture and recreational activities:
- right to accessibility of television, broadcasting and Internet (including the audio description, interpretation in the gestural language and subtitling of the programs, where appropriate);
- (...)



# CONTROLTEC™

Sound Absorbing Panels  
for Acoustic Correction

**Fulgor Service** offers an acoustically sound-absorbing panel with high performance on small and large areas, aesthetically integrated in the style of the room, with the function of controlling the acoustic reverberation "without getting noticed".  
**CONTROLTEC™** is available in various formats and is customizable in style, color and pictures.  
The material by which it is composed is fire resistant, not pulverizes, and does not suffer from bumps and knocks and it is totally inert to chemical/physical attack. The installation does not require skilled workers, the panels are easily removable and do not require maintenance.

## SPOT COLOURS AND PATTERNS

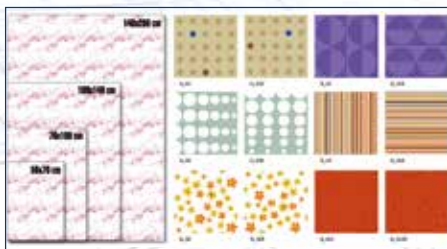

## AVAILABLE FORMATS



## TECHNICAL CHARACTERISTICS

Panel composed of CONTROLTEC™ (technical textile fiber, high sound absorption) properly calibrated to ensure high absorbing performance, thanks to special processing of the fibers which, during the production process, are compacted with increasing density along the thickness. Of unlimited duration, non-toxic, eco-friendly.

**Thickness:** Approximately 40 mm.

**Reaction to fire:** Class B-s1, d0 – LAPI test report n° 1373.ODC0050/10.

**Sound absorption:** sound absorption coefficient for diffuse incidence (UNI EN ISO 354)

frequency [Hz]	250	500	1000	2000	4000
absorption coefficient	0,25	0,55	0,80	0,85	0,85

Sound absorption coefficient for normal incidence (UNI EN ISO 10534-2)

frequency [Hz]	250	500	1000	2000	4000
absorption coefficient	0,10	0,30	0,50	0,80	0,80

Noise Reduction Coefficient NRC (ASTM C423): NRC = 0,70.

**Available formats:** STL\_1 = 1400 mm x 2000 mm; STL\_2 = 1000 mm x 140 mm; STL\_3 = 700 mm x 1000 mm; STL\_4 = 500 mm x 700 mm;  
Each panel can be customized on request, both in subject and color printing.

### Terms of the contract

Insulating layer in panel sizes ... consisting of technical textile fiber with high sound absorption and increasing density along the thickness. Density panel gradient variable average value 40 kg/m<sup>3</sup>, suitably calibrated to improve the performance of acoustic absorption. thickness 40 mm. Thermal resistance of the panel equal to 1.14 m<sup>2</sup>K / W. The surface finishing of the panels can be customized.

### Method of application

Our panel for acoustic correction associates an high technical performance in terms of sound absorption with the total freedom to choose formats and finishes of panels so as to match the acoustic correction with the aesthetic effect of room customization of colors, textures, or images that can be implemented in adherence to the walls or ceiling. The installation is simple, applied directly with velcro, the intervention is completely removable. The product is fire resistant, not pulverized, does not suffer from bumps and knocks and is totally inert to aggressive chemical / physical properties.

# PROJECT and SOLUTIONS

some of our references

**Santa Caterina - Basilica della Natività - Betlemme**



**Chiesa della Trasfigurazione - Monte Tabor - Galilea**



**Santuario del Gethsemani - Gerusalemme - Israele**



**Basilica di San Vitale - Ravenna**



**Cattedrale Sant'Andrea Apostolo - Amalfi - (SA)**



**Cattedrale di San Lorenzo - Genova**





**Cattedrale di San Francesco - Livorno**



**Basilica Ursiana - Cattedrale di Ravenna**



**Basilica Vaticana di Santa Maria in Trastevere - Roma**



**Cattedrale Basilica S. Maria Assunta - Pesaro**



**Chiesa di S. Andrea della Valle - Roma**



**Santuario Santa Maria del Fonte - Caravaggio - (BG)**



**"Cristo Re" Cattedrale della Spezia - (SP)**



**Cattedrale di San Cerbone - Massa Marittima - (GR)**



**Cattedrale di San Zeno - Pistoia**



**Cattedrale di San Venanzio - Fabriano - (AN)**



**Santuario dell'Amore Misericordioso - Collevaleza - Todi**



**Cattedrale di Santo Stefano - Prato**



S. Maria del Mar - Barcellona - Spagna



Cattedrale di Grasse - Francia



Santuario di S. Maria del Pelingo - Acqualagna - Urbino



Cattedrale dell'Assunta - Savona



Cattedrale di San Michele Arcangelo - Albenga - (SV)



Basilica di San Maurizio - Porto Maurizio - (IM)





1987



1989  
1° Amplifier for Processions

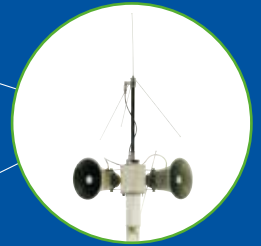

1993  
APP/P Radio Link



1995  
ACTIVO Series Array Speakers



1998  
BIACTIVO Series W.D.S. System



2001  
Automixer 84 DSP



2006  
DIRECTIVITY High Efficiency Directiveness System



2010  
VERTICAL High Efficiency Speakers



2011  
ACTIVO becomes ACTIVO ONE SYSTEM DSP



2013  
M6/M12 Multifunctions Matrix

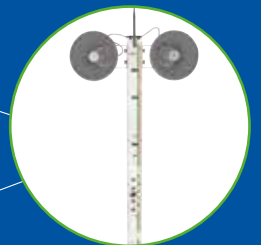

2015  
APP becomes ECO Amplifier for processions



2018  
ACTIVO FOCUS ONE PoS System



2019 – WIFI Control



**FULGOR SERVICE**

SISTEMI DI AMPLIFICAZIONE

FULGOR SERVICE s.n.c.  
Via Caduti del Lavoro, 58  
19021 Arcola (SP) Italy  
Tel. 0187 954488  
Fax 0187 952326

E-mail: [info@fulgorservice.it](mailto:info@fulgorservice.it)

Numero Verde  
**800 - 804067**